

# Woodur

**Portacuchillas Woodur**

**Pag. 38**

**Kit maletín Woodur**

**Pag. 39**

**Cuchillas Woodur**

**Pag. 40**



## Portacuchillas Woodur

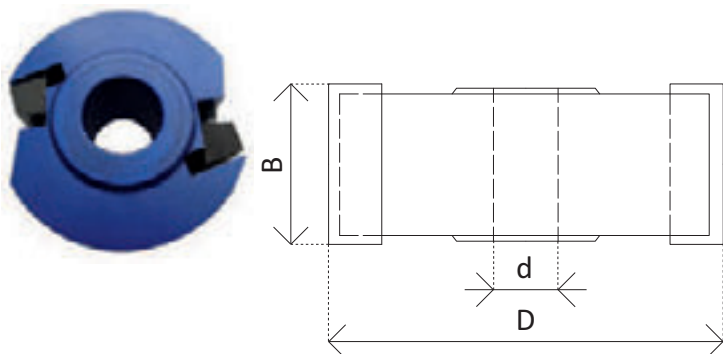

Cabezal Portacuchillas fabricado para trabajar con pares de cuchillas perfiladas, montadas sobre dos centradores, que aseguran la perfecta alineación de las dos cuchillas.

Fabricado en distintas aleaciones y distintos ejes para adaptar a todo tipos de máquinas.

D	d	B	MATERIAL	Ref.
100	30	50	acero	230001
100	30	50	aluminio	230002
120	50	50	acero	230003
120	50	50	aluminio	230004

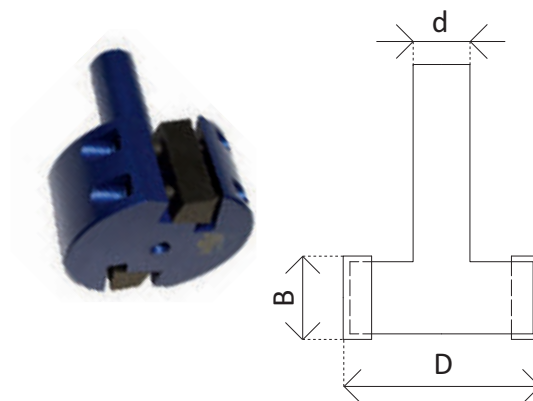

Cabezal Portacuchillas fabricado para trabajar con pares de cuchillas perfiladas, montadas sobre dos centradores, que aseguran la perfecta alineación de las dos cuchillas.

Fabricado en distintas aleaciones, adaptable a cualquier tipo de portapinzas del mercado.

D	d	B	MATERIAL	Ref.
75	20	40	acero	230005
75	20	40	aluminio	230006





## Kit maletín Woodur

Conjunto de artículos Woodur, que incluye un cabezal portacuchillas a elegir entre todas las opciones + 1 juego de 2 cuchillas rectas WOODUR + 6 juegos de 2 cuchillas perfiladas WOODUR serie 9000 (a elegir entre todos los perfiles estándar)+ 1 llave Allen + Caja madera



Conjunto Woodur, que incluye un cabezal portacuchillas a elegir entre todas las opciones + 6 juegos de 2 cuchillas perfiladas WOODUR serie 8000 (a elegir entre todos los perfiles estándar)+ 1 llave Allen + Caja madera.



D	d	B	MATERIAL	NUMERO DE CUCHILLAS
75	20	40	acero	6
75	20	40	aluminio	6
100	30	40	acero	7
100	30	50	aluminio	7
120	50	50	acero	7
120	50	50	aluminio	7



## Cuchillas Woodur 8000 - 9000

Cuchillas fabricadas para adaptarse a todos los portacuchillas existentes en el mercado. Herramienta compuesta de una base de acero, una placa soldada de MD. Nos permite trabajar todo tipo de materiales con seguridad y con una inmejorable calidad, incluidos los materiales como el DM, compactos y aglomerados. Hay una amplia gama de perfiles estándar, que se presentan en este catálogo, pero también damos la posibilidad de hacer cualquier perfil especial que se necesite, solo necesitaremos que nos faciliten un plano del perfil para su fabricación.

### SERIE 8000

Cuchillas perfiladas MD de 40 mm de ancho

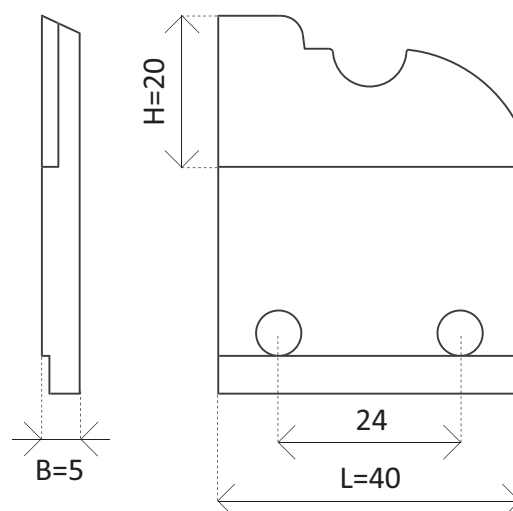

L	H	B	Ref.
40	20	5,0	8001
40	20	5,0	8002
40	20	5,0	8003
40	20	5,0	8004
40	20	5,0	8005
40	20	5,0	8006
40	20	5,0	8007
40	20	5,0	8008
40	20	5,0	8009
40	20	5,0	8010
40	20	5,0	8011
40	20	5,0	8012
40	20	5,0	8013
40	20	5,0	8014
40	20	5,0	8015
40	20	5,0	8016
40	20	5,5	8017
40	20	5,5	8018
40	20	5,5	8019
40	20	5,5	8020
40	20	5,5	8021
40	20	5,5	8022
40	20	5,5	8023
40	20	5,5	8024
40	20	5,5	8025
40	20	5,5	8026
40	20	5,5	8027
40	20	5,5	8028
40	20	5,5	8029
40	20	5,5	8030
40	20	5,5	8031
40	20	5,5	8032
40	20	5,5	8033
40	20	5,5	8034
40	20	5,5	8035
40	20	5,5	8036
40	20	5,5	8037
40	20	5,0	8038
40	20	5,0	8039

L	H	B	Ref.
40	20	5,0	8040
40	20	5,0	8041
40	20	5,0	8042
40	20	5,0	8043
40	20	5,0	8044
40	20	5,0	8045
40	20	5,0	8046
40	20	5,0	8047
40	20	5,0	8048
40	20	5,0	8049
40	20	5,5	8050
40	20	5,5	8051
40	20	5,5	8052
40	20	5,5	8053
40	20	5,5	8054
40	20	5,5	8055
40	20	5,5	8056
40	20	5,5	8057
40	20	5,5	8058
40	20	5,5	8059
40	20	5,5	8060
40	20	5,5	8061
40	20	5,5	8062
40	20	5,5	8063
40	20	5,5	8064
40	20	5,5	8065
40	20	5,5	8066
40	20	5,5	8067
40	20	5,0	8068
40	20	5,0	8069
40	20	5,0	8070
40	20	5,0	8071
40	20	5,0	8072
40	20	5,5	8073
40	20	5,5	8074
40	20	5,5	8075
40	20	5,5	8076
40	20	5,5	8077



## SERIE 9000

Cuchillas perfiladas MD de 50 mm de ancho

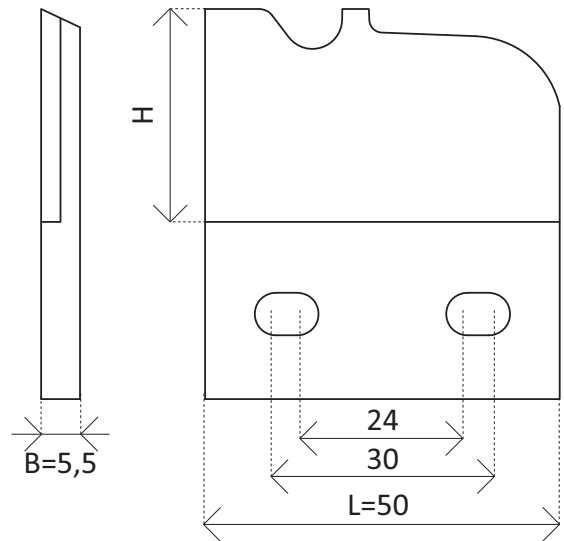

L	H	B	Ref.
50	20	5,5	9001
50	20	5,5	9002
50	20	5,5	9003
50	30	5,5	9004
50	30	5,5	9005
50	20	5,5	9006
50	30	5,5	9007
50	20	5,5	9008
50	20	5,5	9009
50	30	5,5	9010
50	30	5,5	9011
50	20	5,5	9012
50	20	5,5	9013
50	20	5,5	9014
50	20	5,5	9015
50	20	5,5	9016
50	30	5,5	9017
50	20	5,5	9018
50	20	5,5	9019
50	20	5,5	9020
50	20	5,5	9021
50	20	5,5	9022
50	20	5,5	9023
50	20	5,5	9024
50	30	5,5	9025
50	30	5,5	9026
50	20	5,5	9027
50	20	5,5	9028
50	20	5,5	9029
50	20	5,5	9030
50	20	5,5	9031
50	20	5,5	9032
50	30	5,5	9033
50	30	5,5	9034
50	30	5,5	9035
50	30	5,5	9036
50	30	5,5	9037
50	30	5,5	9038
50	20	5,5	9039
50	20	5,5	9040
50	30	5,5	9041
50	20	5,5	9042
50	20	5,5	9043
50	30	5,5	9044
50	30	5,5	9045
50	20	5,5	9046
50	30	5,5	9047
50	20	5,5	9048
50	20	5,5	9049
50	20	5,5	9050
50	20	5,5	9051

L	H	B	Ref.
50	30	5,5	9052
50	30	5,5	9053
50	30	5,5	9054
50	30	5,5	9055
50	20	5,5	9056
50	20	5,5	9057
50	30	5,5	9058
50	30	5,5	9059
50	30	5,5	9060
50	20	5,5	9061
50	20	5,5	9062
50	30	5,5	9063
50	20	5,5	9064
50	20	5,5	9065
50	20	5,5	9066
50	20	5,5	9067
50	30	5,5	9068
50	20	5,5	9069
50	20	5,5	9070
50	20	5,5	9071
50	20	5,5	9072
50	30	5,5	9073
50	30	5,5	9074
50	20	5,5	9075
50	30	5,5	9076
50	30	5,5	9077
50	20	5,5	9078
50	30	5,5	9079
50	20	5,5	9080
50	20	5,5	9081
50	30	5,5	9082
50	20	5,5	9083
50	20	5,5	9084
50	30	5,5	9085
50	20	5,5	9086
50	30	5,5	9087
50	30	5,5	9088
50	30	5,5	9089
50	20	5,5	9090
50	20	5,5	9091
50	30	5,5	9092
50	20	5,5	9093
50	20	5,5	9094
50	20	5,5	9095
50	30	5,5	9096
50	20	5,5	9097
50	20	5,5	9098
50	30	5,5	9199
50	30	5,5	9100
50	20	5,5	9101



# CUCHILLAS PERFILADAS CON PLACAS DE METAL DURO



9001

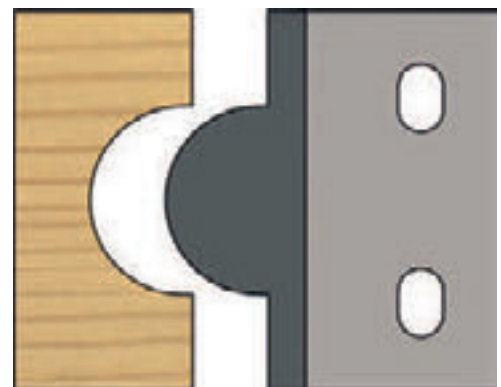

9002



9003

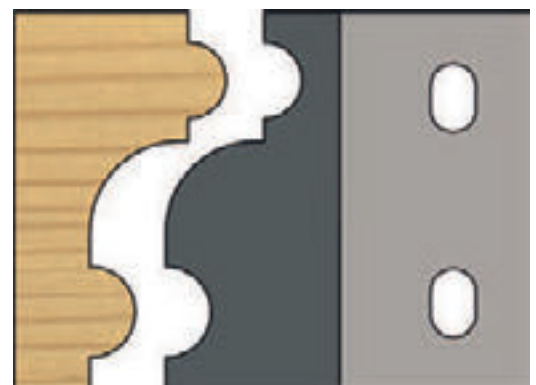

9004



9005



9006



9007



9008



9009



9010



9011

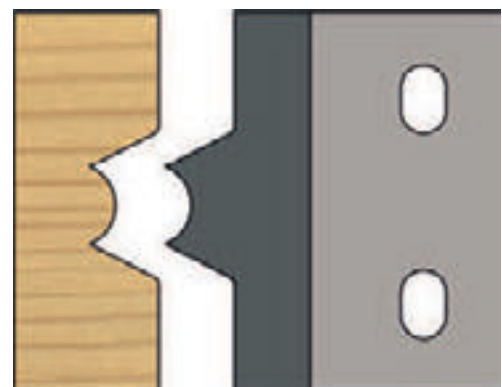

9012



9013



9014



9015



9016



9017

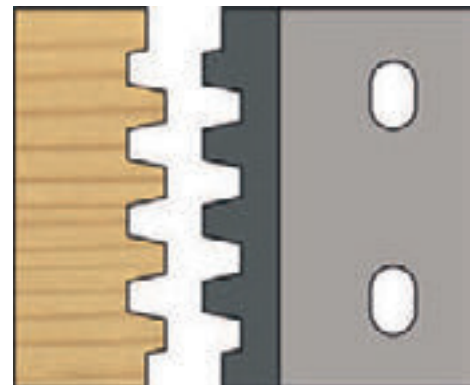

9018

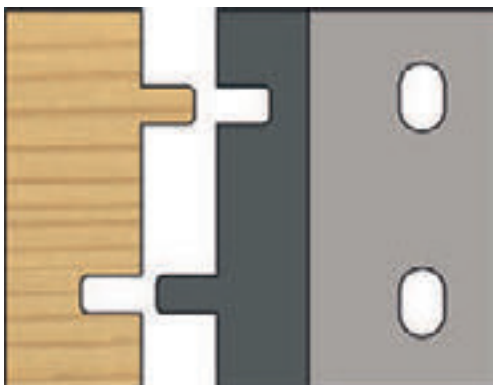

9019



9020



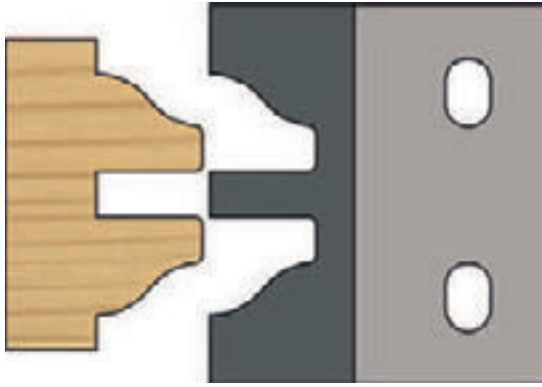

9021

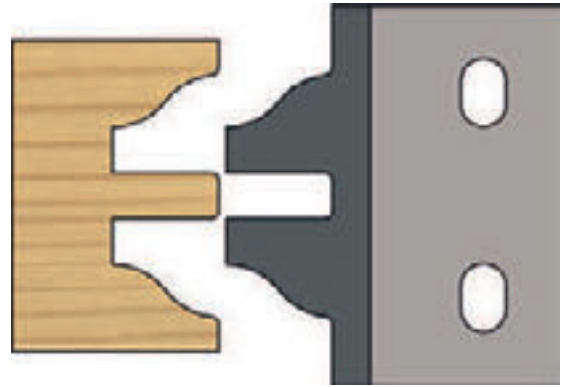

9022

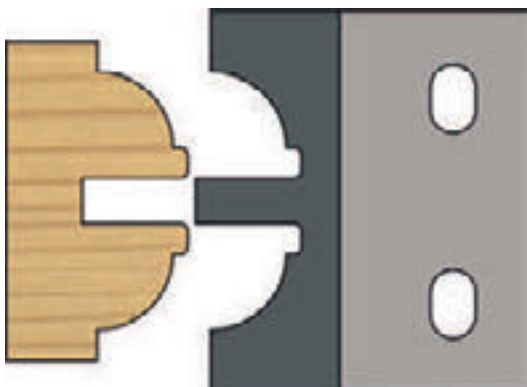

9023

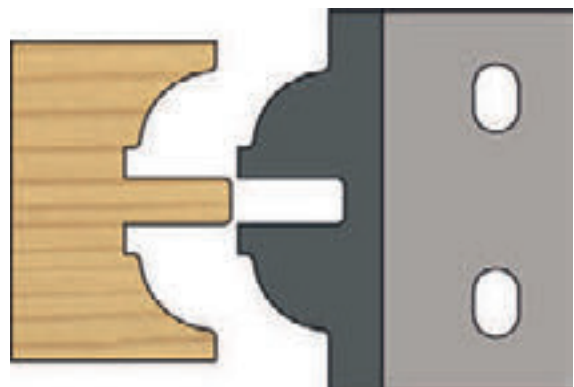

9024

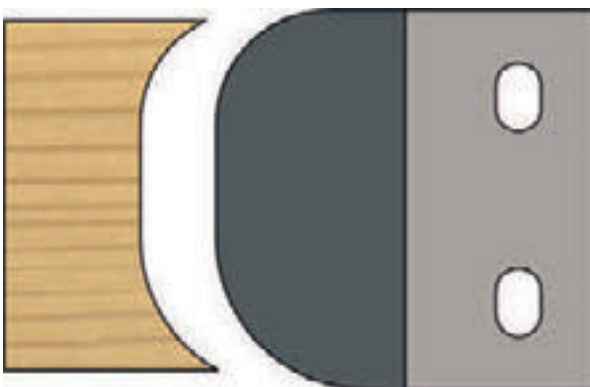

9025



9026

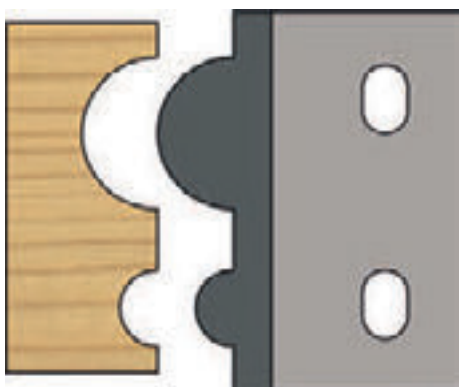

9027



9028

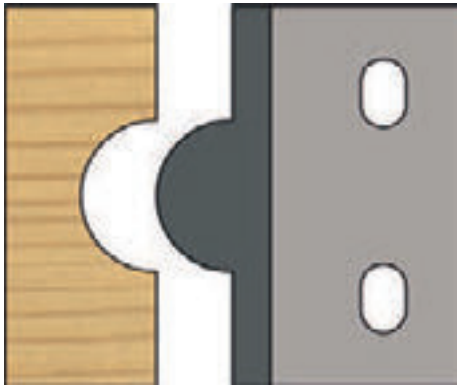

9029

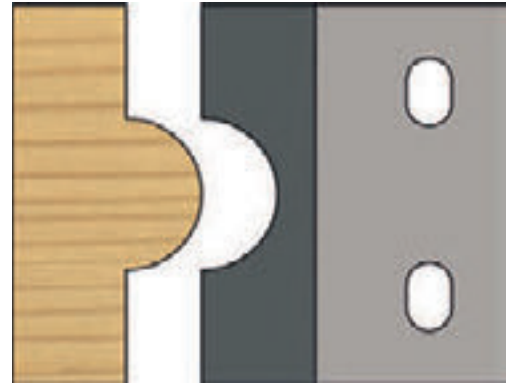

9030

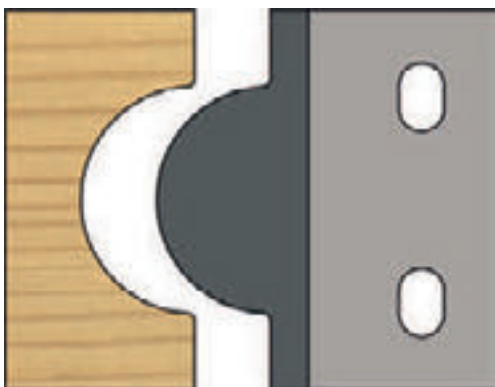

9031



9032



9033



9034

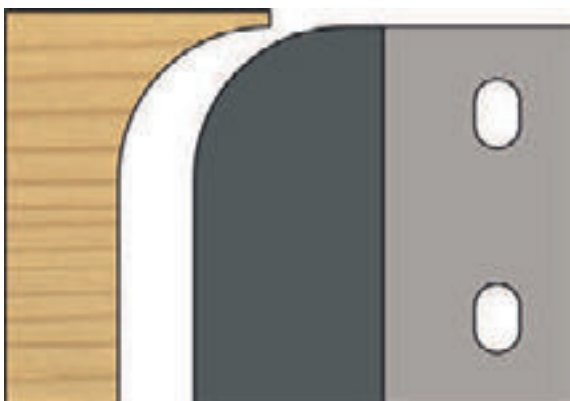

9035

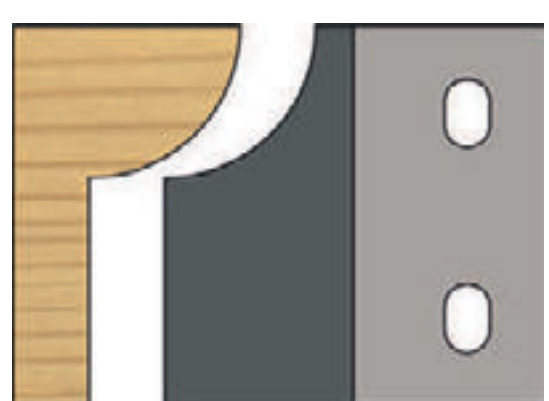

9036

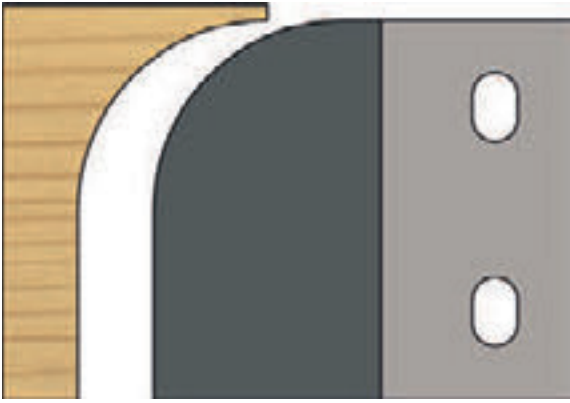

9037



9038

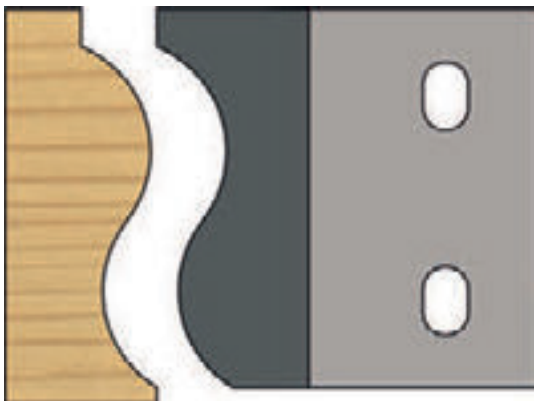

9039

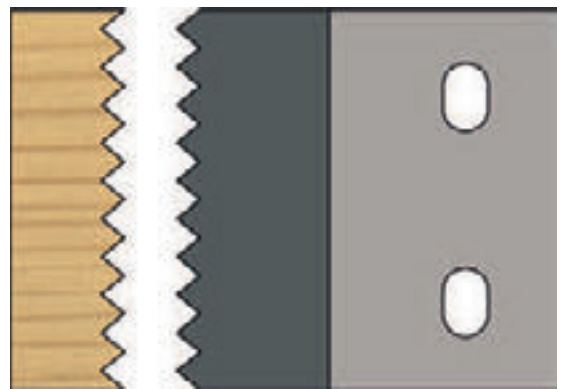

9040



9041



9042



9043

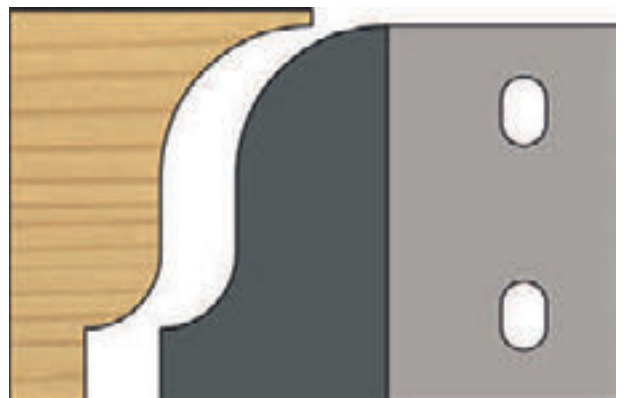

9044



9045



9046



9047

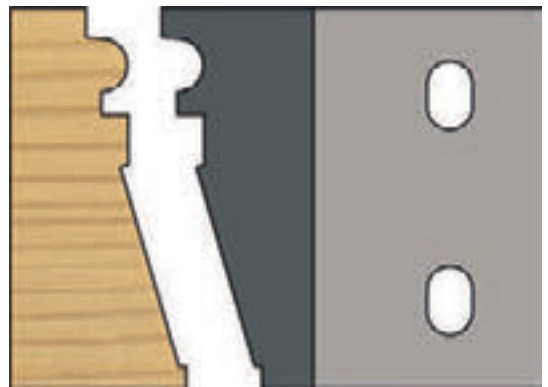

9048



9049

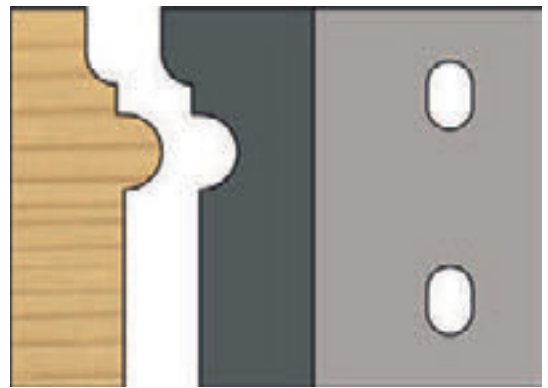

9050



9051

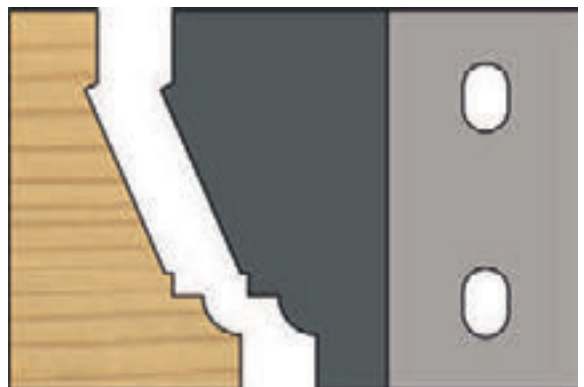

9052



9053



9054



9055

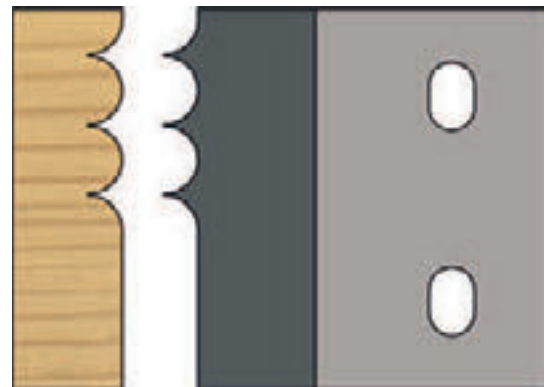

9056

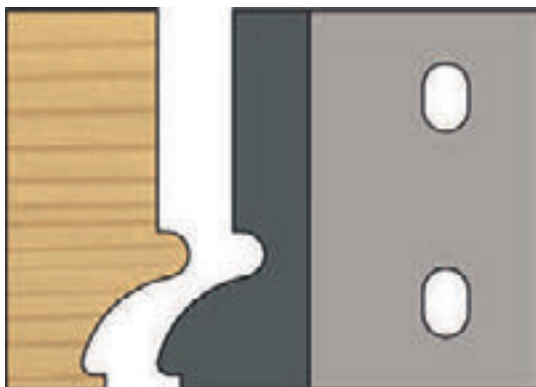

9057



9058



9059



9060

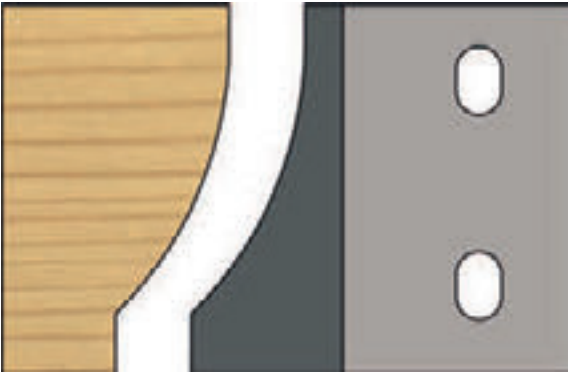

9061



9062

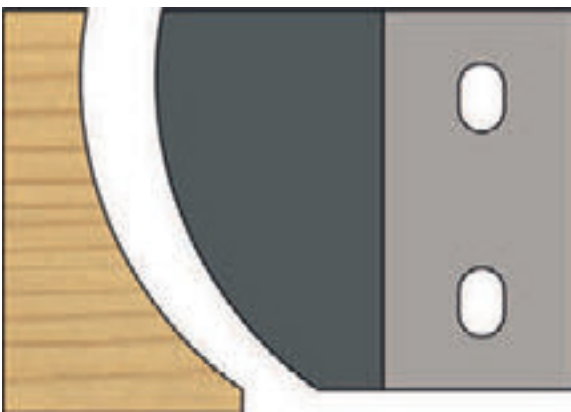

9063



9064



9065

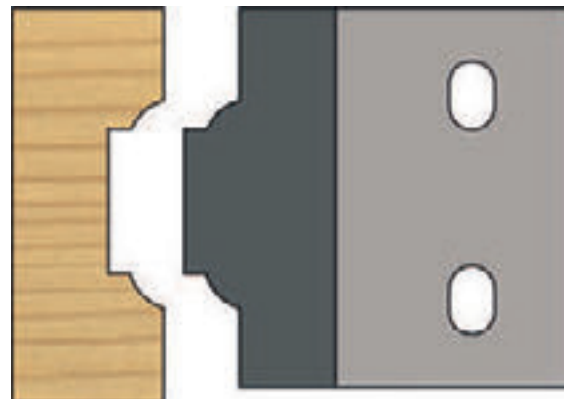

9066



9067



9068



9069

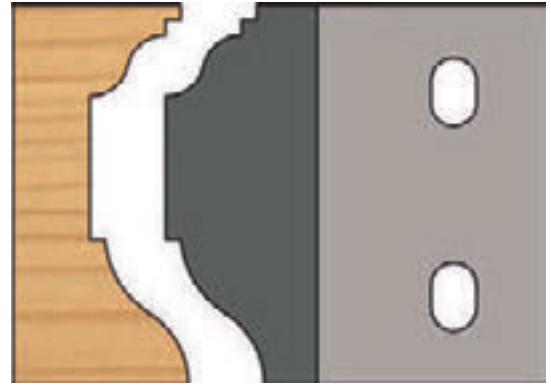

9070



9071

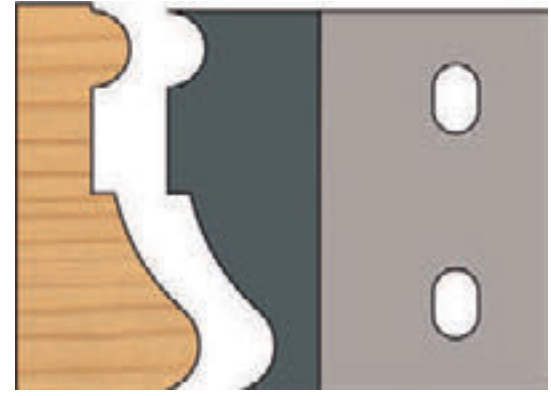

9072



9073



9074



9075



9076



9077



9078



9079



9080



9081



9082

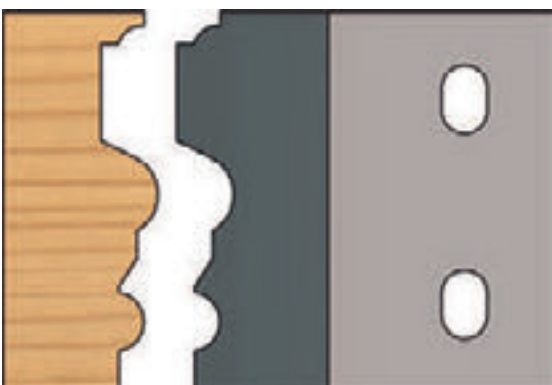

9083



9084





9085



9086



9087



9088



9089

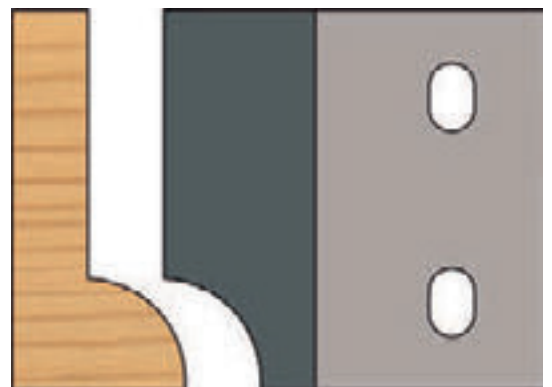

9090



9091

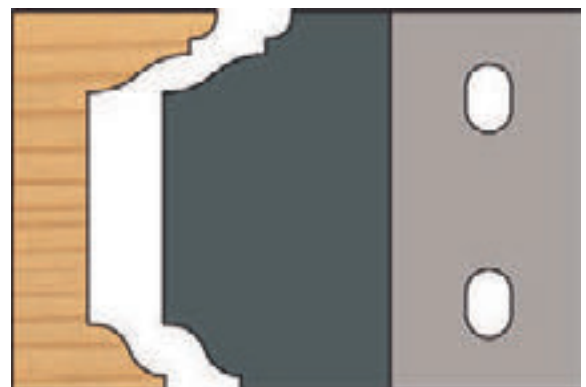

9092



9093



9094

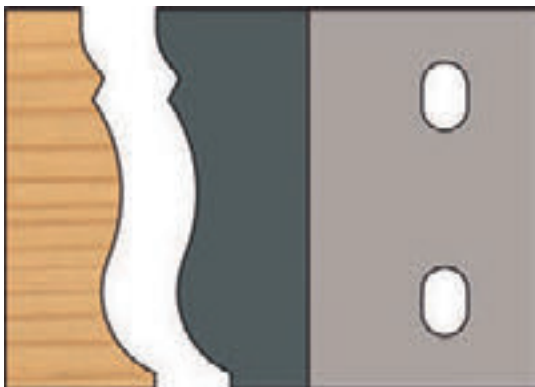

9095

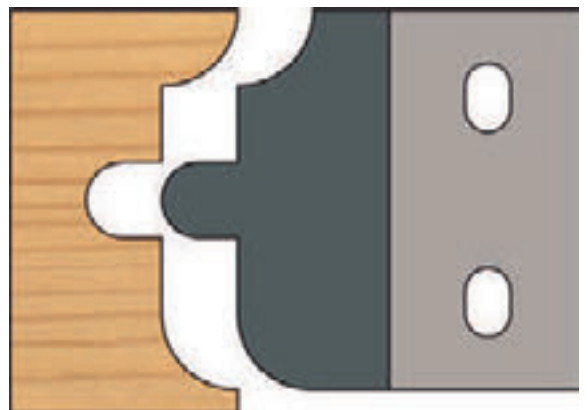

9096

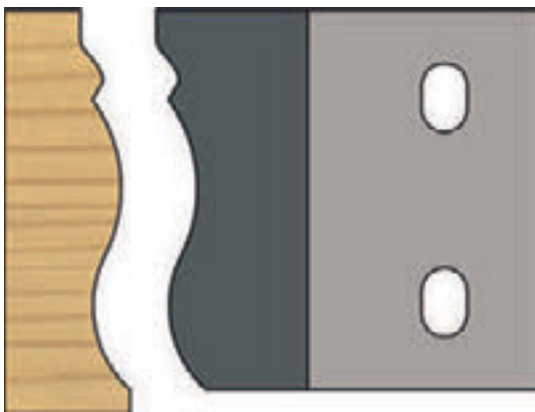

9097



9098



9099



9100



8001



8002

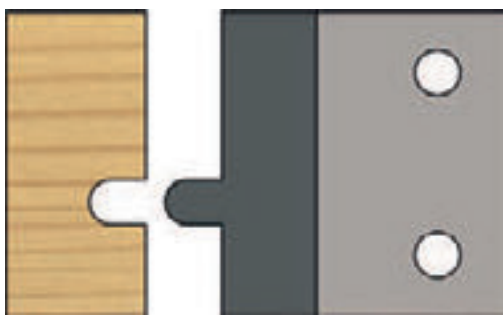

8003



8004



8005

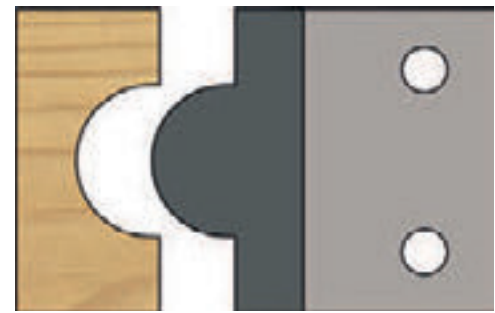

8006



8007



8008



8009



8010

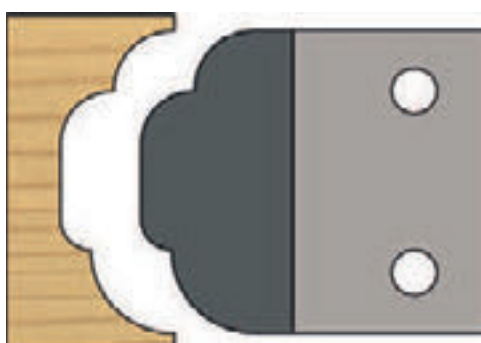

8011



8012



8013



8014



8015



8016

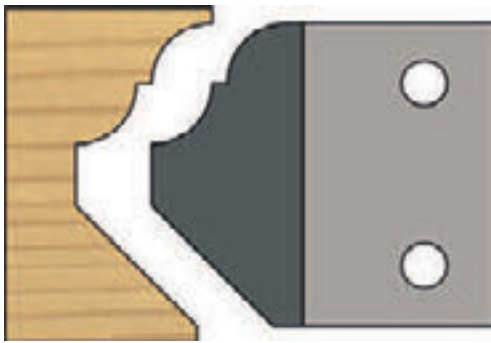

8017

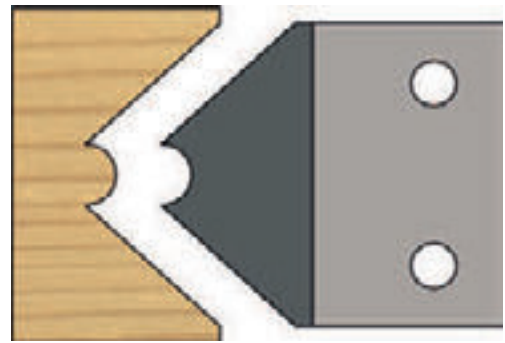

8018



8019



8020



8021



8022



8023



8024



8025



8026

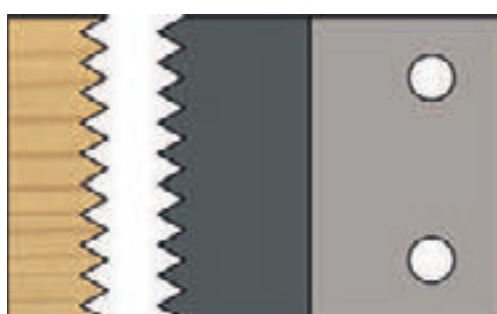

8027



8028



8029



8030



8031



8032



8033



8034



8035



8036



8037



8038



8039



8040



8041



8042



8043



8044



8045



8046



8047



8048





8049



8050

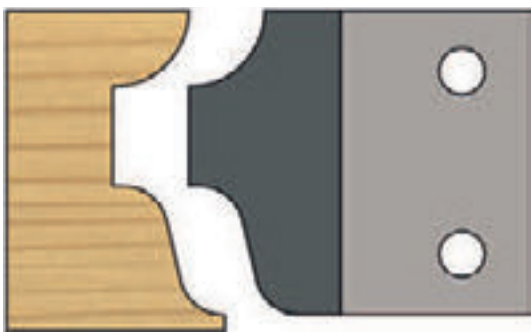

8051



8052

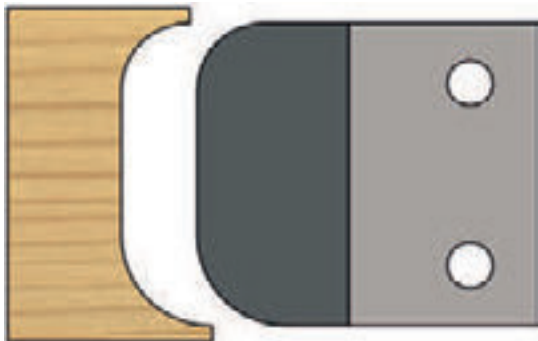

8053

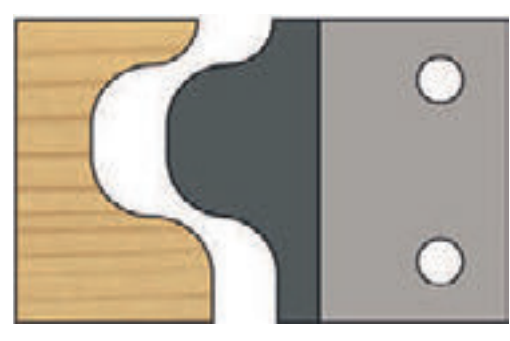

8054

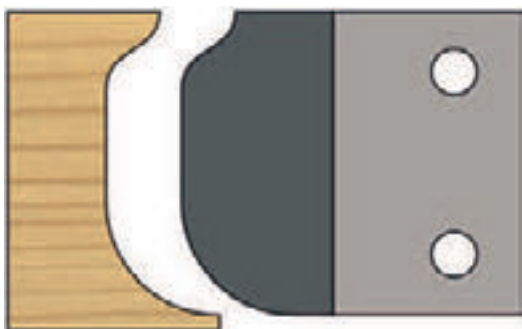

8055



8056

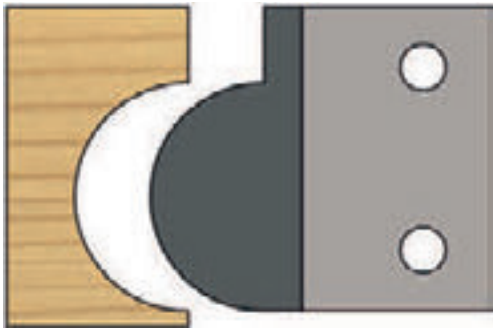

8057



8058



8059



8060



8061



8062



8063



8064



8065

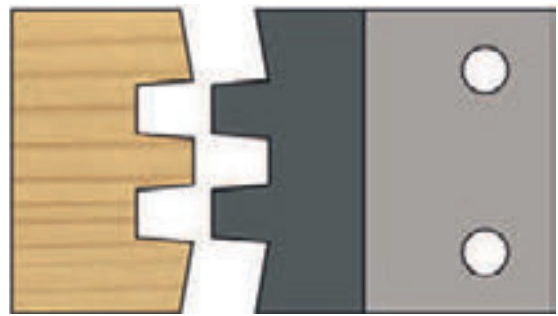

8066



8067



8068



8069

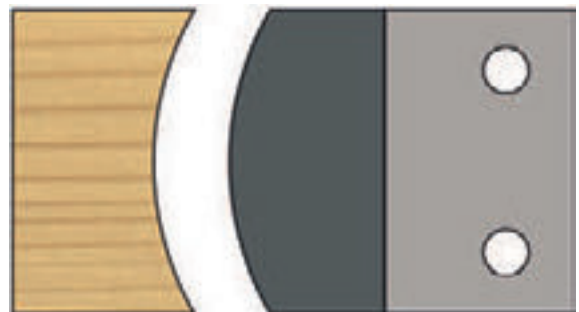

8070



8071

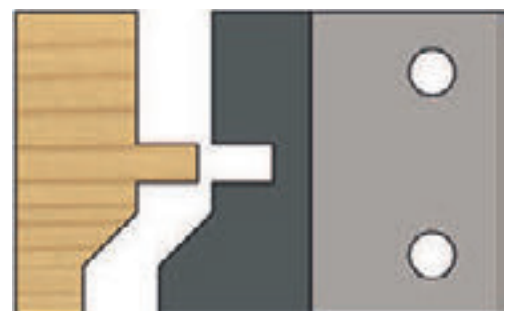

8072



8073

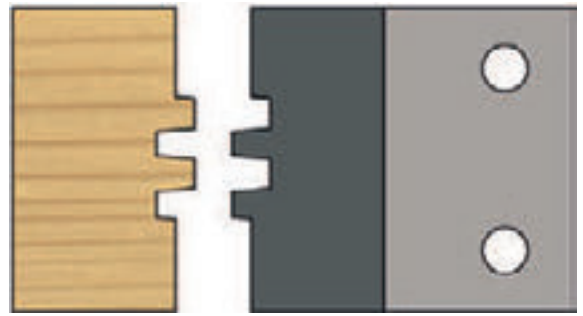

8074



8075



8076



8077